



**Technical Service
BULLETIN**

May 23, 2005

Title:

**SECURITY SYSTEM V3 (RS3200)
IGNITION-CONTROLLED DOOR
LOCK PROGRAMMING**

Models:

'05 RAV4 & Scion xA

AX003-05
ACCESSORIES

Introduction The Ignition–Controlled Door Lock/Unlock feature for the PPO/DIO V3 (RS3200) Security System is programmable and can be set to “ON” or “OFF” depending on customer preference. RS3200 kits produced for the 2005 model year RAV4 and Scion tC with the manufactured date range identified in the Parts Identification section of this bulletin may have been programmed “OFF” and require reprogramming depending on the customer’s preference. The programming instructions are in the RS3200 Owner’s Guide and in this bulletin.

- Applicable Vehicles**
- **2005** model year **RAV4** and **Scion xA** vehicles.

Warranty Information

OP CODE	DESCRIPTION	TIME	OFF	T1	T2
AX5001	Security System Programming	0.2	08586–4A871–BB	72	74

Applicable Warranty*:

This repair is covered under the Toyota Comprehensive Warranty. This warranty is in effect for 36 months or 36,000 miles, whichever occurs first, from the vehicle’s in-service date.

* Warranty application is limited to correction of a problem based upon a customer’s specific complaint.



Parts Identification

TOYOTA PART NUMBER	PART NAME	MFG DATE RANGE	DATE CODE
08586-4A871-BB	RAV4 V3 (RS3200)	January 17, 2005 through February 21, 2005	17A05 – 21B05
08586-52971	Scion xA V3 (RS3200)	January 2, 2005 through February 21, 2005	02A05 – 21B05

2005 model year RAV4 and Scion tC RS3200 kits manufactured with date codes listed above may require reprogramming depending on customer preference.

Starting February 22, 2005, the ECU will be programmed to the “ON” position and can be identified by a black dot on the outside box. If the box has the black dot, it will not be necessary to program the ECU.

Date Code Identification

Sample Label

DESCRIPTION 2005 xA RS3200 0018
 PART NO. **08586-52971**
 QTY: 1 **22B05**
TOYOTA GENUINE PARTS
 398.0 Grams
 TOYOTA MOTOR SALES, U.S.A. INC.
 PACKAGES IN UNITED STATES FROM
 JAPANESE AND U.S. COMPONENTS

Black Dot on Box

**Sample Date Code:
22B05 (P/N 08586-52971)**

22	B	05
Day of Production	Month of Production	Year of Production
01 – 31	A – L Jan – Dec	05 = 2005

Countermeasure Parts Produced After: 22B05 (February 22, 2005)

**Programming
Procedure****Ignition-Controlled Automatic Door Lock/Unlock**

The RS3200 is factory set to automatically lock your vehicle's doors when you turn the ignition key to "ON" or "START" and unlock the doors when you turn the key back to "ACC" or "LOCK." To change the programming of this feature, follow the procedure below.

1. Before you begin:
 - A. Open the driver's door.

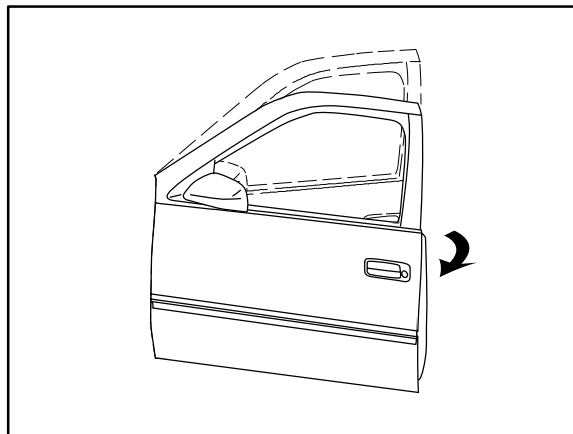

- B. Remove the key from the ignition switch.

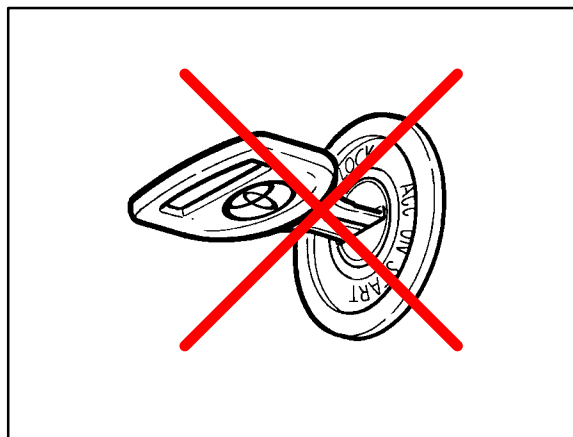

2. Start the programming procedure.
(Complete these steps within 30 seconds.)
 - A. Insert the key into the ignition switch and turn it from "LOCK" to "ON" 5 times (ending at "ON").

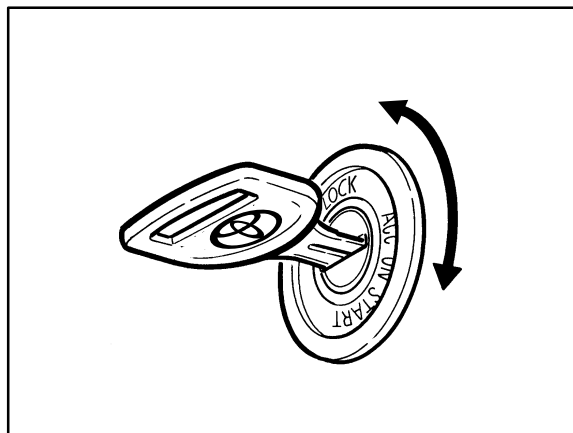

**Programming
Procedure**
(Continued)

- B. The tail and marker lights flash once, and the buzzer chirps once.

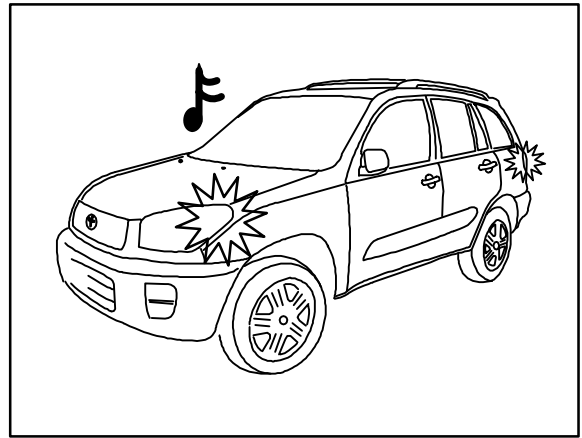

- C. The Status Monitor's LED (or the engine immobilizer system's LED) turns on for 30 seconds.

NOTE:

If the system does not activate the lights and buzzer, start over from step 1.

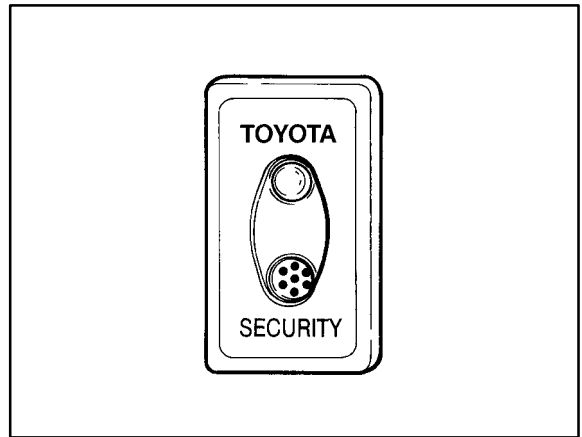

3. Select the operating mode below.
Follow choice "A" for "ON" or "B"
for "OFF."

- A. Close the door.
The ignition-controlled door lock function will be "ON."
- B. Close, then open and close the door again.
The ignition-controlled door lock function will be "OFF."

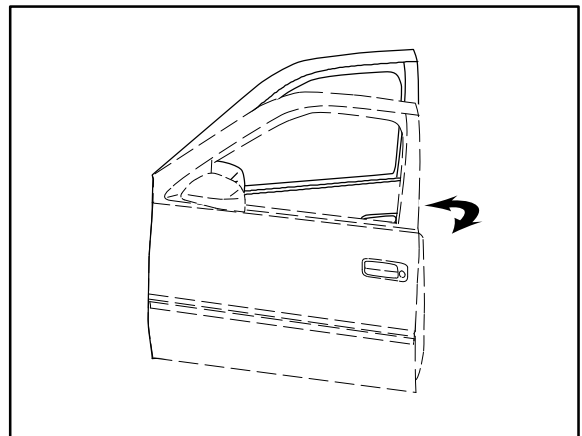

Programming Procedure
(Continued)

4. Complete the programming procedure.
 - A. Turn the ignition key back to "LOCK."

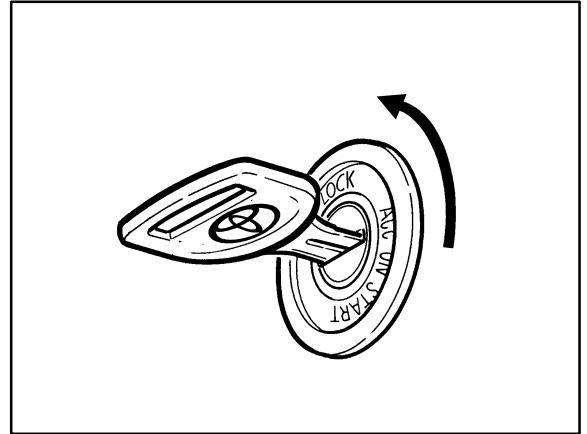

- B. The tail and marker lights flash once and the buzzer chirps once when the system is set for ignition-controlled door lock function "ON" and twice for ignition-controlled door lock function "OFF."
If this does not happen, perform the programming procedure again.
Programming is now complete.

