

**TSB REVISION NOTICE:**

- **November 8, 2005:** The anti-squeal shims in the second illustration of the Repair Procedure have been clarified for easier identification.  
Previous versions of this TSB should be discarded.

**Introduction** Some 2004 Scion xA and xB models may experience a brake squeaking noise when backing up and applying the brakes. To reduce this noise, the shape of the brake pad and anti-squeal shims have been changed and an additional amount of anti-squeak grease has been applied during assembly.

- Applicable Vehicles**
- **2004** model year **Scion xA** and **xB** vehicles produced **BEFORE** the Production Change Effective VINs shown in the Production Change Information section.

**Warranty Information**

**Replace Disc:**

OP CODE	DESCRIPTION	TIME	OFF	T1	T2
473011	R & R Front Disc	0.6	43512-52080	91	99
Combo A	Opposite Side	0.3			
Combo B	Front Disc Brake Caliper Assembly (One Side)	0.2			
Combo C	Front Disc Brake Caliper Assembly (Opposite Side)	0.2			

**OR**

**Resurface Disc:**

OP CODE	DESCRIPTION	TIME	OFF	T1	T2
473025	Grind Front Disc (On Car Only)	1.3	43512-52080	91	99
Combo A	Opposite Side	1.0			
Combo B	Front Disc Brake Caliper Assembly (One Side)	0.2			
Combo C	Front Disc Brake Caliper Assembly (Opposite Side)	0.2			

**Applicable Warranty\*:**

**This repair is covered under the Toyota Comprehensive Warranty. This warranty is in effect for 36 months or 36,000 miles, whichever occurs first, from the vehicle's in-service date.**

\* Warranty application is limited to correction of a problem based upon a customer's specific complaint.



**Production Change Information**

MODEL	PLANT	PRODUCTION CHANGE EFFECTIVE VIN
Scion xA	Takaoka	JTKKT624150094098
Scion xB	Takaoka	JTLKT324850196170
	Central	JTLKT324754000020

**Parts Information**

PREVIOUS PART NUMBER	CURRENT PART NUMBER	PART NAME	QTY
04465-52170	04465-52210	Pad Kit, Disc Brake, FR	1
04945-52050	04945-52060	Shim Kit, Anti-Squeal, FR	1
		Anti-Squeal Grease	1

**Repair Procedure**

1. Replace or resurface front disc rotors with the On-Car Brake Lathe according to the applicable Repair Manual to within serviceable limits.
2. Add anti-squeal grease to the inner and outer brake pads in a 40 mm wide by 22.2 mm tall (1.58 in. wide by 0.87 in. tall) square patch centered on the back of each brake pad as shown below.

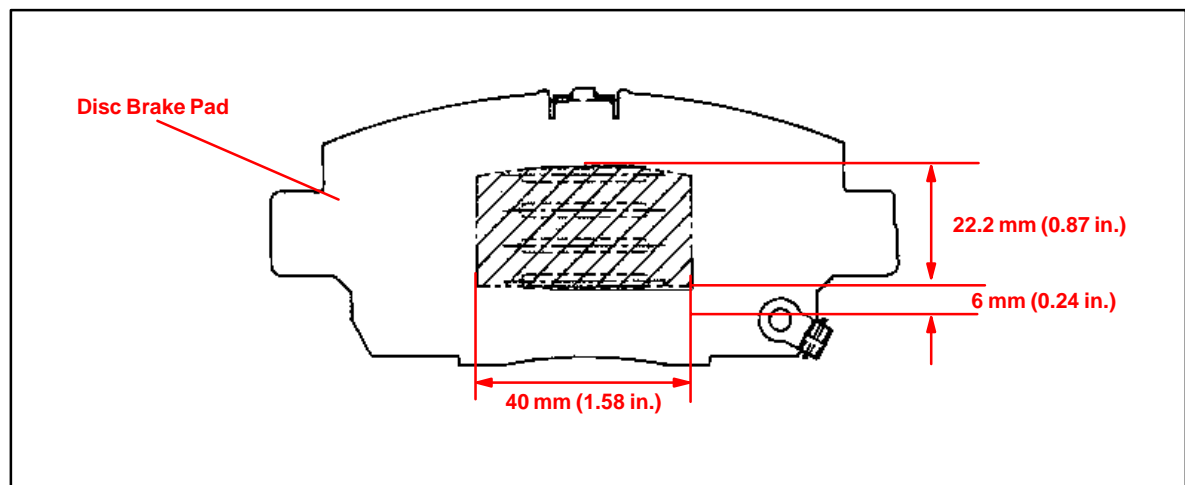

**NOTE:**  
It is necessary to apply the anti-squeal grease to both inner and outer brake pads.

**Repair  
Procedure**  
(Continued)

3. Install the anti-squeal shims No. 1 and No. 2 on the brake pads. Do NOT wipe off grease if it overflows from the slit in the anti-squeal shims.

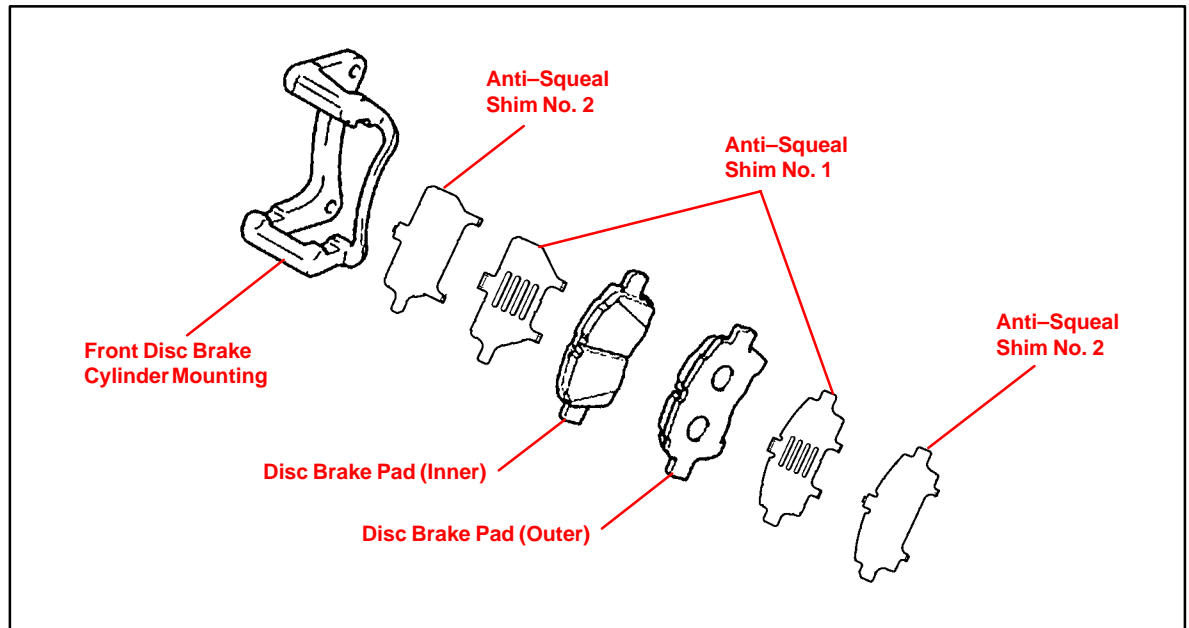

4. Install the front disc brake pads and the front anti-squeal kit assembly on the vehicle.
5. Perform road test.